

ESE 2025

UPSC ENGINEERING SERVICES EXAMINATION

Main Examination

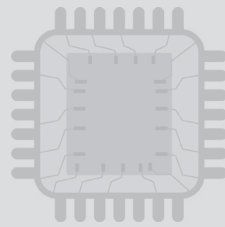

Electronics & Telecommunication Engineering

Topicwise *Conventional* Solved Papers

Paper-II

25 Years
SOLVED
PAPERS

- ✓ Thoroughly revised and updated
- ✓ Fully solved with explanations
- ✓ Also useful for State Engineering Services Exams



www.madeeasypublications.org



MADE EASY Publications Pvt. Ltd.

Corporate Office: 44-A/4, Kalu Sarai (Near Hauz Khas Metro Station), New Delhi-110016

E-mail: infomep@madeeasy.in

Contact: 9021300500

Visit us at: www.madeeasypublications.org

ESE-2025 : Main Examination

E&T Engineering : Paper-II | Conventional Solved Questions : (2000-2024)

© Copyright, by MADE EASY Publications.

All rights are reserved. No part of this publication may be reproduced, stored in or introduced into a retrieval system, or transmitted in any form or by any means (electronic, mechanical, photo-copying, recording or otherwise), without the prior written permission of the above mentioned publisher of this book.

1st Edition : 2008

2nd Edition : 2009

3rd Edition : 2010

4th Edition : 2011

5th Edition : 2012

6th Edition : 2013

7th Edition : 2014

8th Edition : 2015

9th Edition : 2016

10th Edition : 2017

11th Edition : 2018

12th Edition: 2019

13th Edition: 2020

14th Edition: 2022 (Feb)

15th Edition: 2022 (July)

16th Edition: 2023

17th Edition: 2024

MADE EASY PUBLICATIONS has taken due care in collecting the data and providing the solutions, before publishing this book. In spite of this, if any inaccuracy or printing error occurs then MADE EASY PUBLICATIONS owes no responsibility. MADE EASY PUBLICATIONS will be grateful if you could point out any such error. Your suggestions will be appreciated.



B. Singh (Ex. IES)

Director's Message

In past few years ESE Main exam has evolved as an examination designed to evaluate a candidate's subject knowledge. Studying engineering is one aspect but studying to crack prestigious ESE exam requires altogether different strategy, crystal clear concepts and rigorous practice of previous years' questions. ESE mains being conventional exam has subjective nature of questions, where an aspirant has to write elaborately - step by step with proper and well labeled diagrams and figures. This characteristic of the main exam gave me the aim and purpose to write this book. This book is an effort to cater all the difficulties being faced by students during their preparation right from conceptual clarity to answer writing approach.

MADE EASY Team has put sincere efforts in solving and preparing accurate and detailed explanation for all the previous years' questions in a coherent manner. Due emphasis is made to illustrate the ideal method and procedure of writing subjective answers. All the previous years' questions are segregated subject wise and further they have been categorised topic-wise for easy learning and helping aspirants to solve all previous years' questions of particular area at one place. This feature of the book will also help aspirants to develop understanding of important and frequently asked areas in the exam.

I would like to acknowledge the efforts of entire MADE EASY team who worked hard to solve previous years' questions with accuracy. I hope this book will stand upto the expectations of aspirants and my desire to serve the student community by providing best study material will get accomplished.

B. Singh (Ex. IES)
CMD, MADE EASY Group

1. Analog and Digital Communication Systems 1-102	5. Signals and Systems395-460
1. Analog Communication Systems 1	1. Basics of Signals and Systems 395
2. Random Variables, Random Process & Noise27	2. Continuous and Discrete Time LTI Systems ... 399
3. Digital Communication Systems47	3. Fourier Series 411
4. Information Theory86	4. Continuous Time Fourier Transform 415
2. Control Systems103-237	5. Laplace Transform..... 425
1. Basics, Block Diagrams & Signal Flow Graphs....103	6. Discrete Time Fourier Transform..... 432
2. Time Domain Analysis 122	7. Z-Transform 435
3. Routh-Hurwitz Stability Criterion..... 161	8. Digital Filters: Design and Applications ... 453
4. Root Locus 169	6. Computer Organization and Architecture461-523
5. Frequency Domain Analysis..... 193	1. Basics of Computer Organization and Architecture 461
6. Compensators and Controllers 219	2. I/O Organization and Pipelining 469
7. State Space Analysis..... 235	3. Memory Organization 473
3. Microprocessors and Microcontrollers238-279	4. Data Representation and Programming... 482
1. 8085 Microprocessor..... 238	5. Data Structures 506
2. 8086 Microprocessor..... 262	6. Operating Systems and Data Bases 509
3. Interfacing Devices..... 270	7. Advanced Communication...524-588
4. Electromagnetics280-394	1. Communication and Cellular Networks.... 524
1. Vector Calculus & Maxwell's Equations..... 280	2. Microwave and Satellite Communication Systems..... 540
2. Uniform Plane Waves 300	3. Fibre Optic Communication Systems 564
3. Transmission Lines..... 318	8. Advanced Electronics589-615
4. Waveguides 341	
5. Antennas and Basics of Radar 373	



1

Analog and Digital Communication Systems

Revised Syllabus of ESE: Random signals, noise, probability theory, information theory; Analog versus digital communication & applications: Systems- AM, FM, transmitters/receivers, theory/practice/ standards, SNR comparison; Digital communication basics: Sampling, quantizing, coding, PCM, DPCM, multiplexing-audio/video; Digital modulation: ASK, FSK, PSK; Multiple access: TDMA, FDMA, CDMA.

1. Analog Communication Systems

- 1.1** A measuring system is used to calibrate the setting on a CW signal generator. Two adjacent nulls are found on the coaxial slotted line. The scale readings are 12.4 cm and 25.7 cm.
- What is the wavelength and frequency of the signal generator at this setting?
 - What cutoff frequency should be selected for the low pass filter?
 - What must the local oscillator frequency be if the IF amplifier frequency is 60 MHz?
 - What attenuator should be selected to reduce the reflected power by 12 dB?

[20 marks : 2000]

Solution:

(i) $\frac{\lambda}{2}$ = distance between two adjacent nulls

$\Rightarrow \frac{\lambda}{2} = (25.7 - 12.4) = 13.3$

$\Rightarrow \lambda = 2 \times 13.3 = 26.6 \text{ cm}$ **Ans.**

Frequency $f = \frac{c}{\lambda}$

$\Rightarrow f = \frac{3 \times 10^{10}}{26.6} = 1.1278 \times 10^9 \text{ Hz} = 1.1278 \text{ GHz}$

(ii) Cutoff frequency of the LPF,

$f_c = 1.1278 \text{ GHz}$ **Ans.**

(iii) $f_{LO} = f_c + f_{IF} = 1.1278 \times 10^9 + 60 \times 10^6$

$f_{LO} = (1.1278 + 0.06) \times 10^9 = 1.1878 \text{ GHz}$ **Ans.**

(iv) A resistive circuit whose relation is as $10 \log \frac{P_i}{P_o} = 12$ is used as attenuator.

- 1.2** A 10 MHz carrier is frequency modulated using a modulating signal $e_m = E_m \sin 10^3 \pi t$. The resultant FM signal has frequency deviation of 5 kHz.

- Calculate the modulation index of the FM wave.
- What should be the capture range of a PLL used for demodulation of this signal?
- Derive the result of part (b).

[3 + 6 + 6 marks : 2001]

Solution:

(i) Modulation index, $m_f = \frac{\Delta f}{f_m}$

where, $\Delta f \rightarrow$ frequency deviation and $f_m \rightarrow$ maximum frequency component of modulating signal.

$$m_f = \frac{5 \times 10^3}{10^3 \pi / 2\pi} = \frac{2 \times 5 \times 10^3}{10^3} = 10 \quad \text{Ans.}$$

(ii) $\Delta f = 5 \text{ kHz} = 5 \times 10^3 \text{ Hz}$

Input frequency $f_1 = \frac{10^3}{2} = 500 \text{ Hz}$

$$\begin{aligned} \therefore \text{Capture range (total)} &\cong 2\sqrt{f_1 \Delta f} \\ &\cong 2\sqrt{500 \times 5000} \\ &= 3.162 \times 10^3 \text{ Hz} = 3.162 \text{ kHz} \end{aligned}$$

(iii) When PLL is not initially locked to the signal, the frequency of the VCO will be free running frequency f_0 . The phase angle difference between the signal and the VCO output voltage will be

$$\phi = (\omega_s \cdot t + \theta_s) - (\omega_o \cdot t + \theta_o) = (\omega_s - \omega_o)t + \Delta\theta$$

thus the phase angle difference does not remain constant but will change with time at a rate given by

$$\frac{d\phi}{dt} = \omega_s - \omega_o$$

The phase detector output voltage will therefore not have a dc component but will produce an ac voltage with a triangular waveform of peak amplitude $K_\phi(\pi/2)$ and a fundamental frequency $(f_s - f_o) = \Delta f$. The low pass filter (LPF) is a simple RC network having transfer function

$$T(jf) = \frac{1}{(1 + jff_1)}$$

where $f_1 = \frac{1}{2\pi RC}$ is the 3-dB point of LPF. In the slope portion of LPF where $\left(\frac{f}{f_1}\right)^2 \gg 1$ then

$$T(f) \cong \frac{f_1}{jf}$$

The fundamental frequency term supplied to the LPF by the phase detector will be the difference frequency $\Delta f = f_s - f_o$. If $\Delta f > 3f_1$, the LPF transfer function will be approximately

$$T(\Delta f) \simeq \frac{f_1}{\Delta f} = \frac{f_1}{(f_s - f_o)}$$

The voltage V_c to drive the VCO is

$$V_c = V_e \times T(f) \times A$$

or

$$V_{c \max} = V_{e \max} \times T(f) \times A$$

$$V_{c \max} = \pm K_\phi \left(\frac{\pi}{2}\right) A \left(\frac{f_1}{\Delta f}\right) \quad \left(\because V_{e \max} = \pm K_\phi(\pi/2)\right)$$

Then corresponding value of maximum phase shift is

$$(f - f_o)_{\max} = K_v V_{c \max} = \pm K_v K_\phi \left(\frac{\pi}{2}\right) A \left(\frac{f_1}{\Delta f}\right)$$

For the acquisition of signal frequency, we should put $f = f_s$, so that maximum signal frequency range that can be required by PLL is

$$(f_s - f_o)_{\max} = K_v K_\phi \left(\frac{\pi}{2} \right) A \left(\frac{f_1}{\Delta f_c} \right)$$

Now
$$\Delta f_c = (f_s - f_o)_{\max}$$

So
$$(\Delta f_c)^2 = K_v K_\phi \frac{\pi}{2} A f_1$$

But
$$K_v K_\phi \frac{\pi}{2} A = \Delta f_L$$

$$\therefore \Delta f_c = \sqrt{f_1 \Delta f_L}$$

Therefore total capture range

$$\Delta f_c = 2\sqrt{f_1 \Delta f_L}$$

1.3 Explain how frequency modulation may be obtained from a phase modulator. Diagrammatically compare the amplitude modulation, frequency modulation and phase modulation in respect of change in amplitude, frequency and phase when the carrier is modulated with a step function.

[8 marks : 2004]

Solution:

Frequency modulation from a phase modulator:

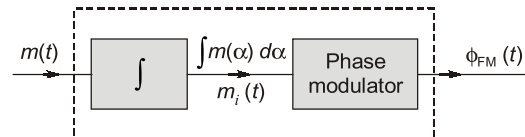

The waveform $m_i(t)$ is derived as the integral of the modulating signal $m(t)$, i.e.,

$$m_i(t) = k' \int_{-\infty}^t m(\alpha) d\alpha$$

where k' is sensitivity of phase modulator.

Output of phase modulator is

$$v(t) = A \cos [\omega_c t + k'' m_i(t)]$$

where k'' is sensitivity of phase modulator

$$v(t) = A \cos \left[\omega_c t + k \int_{-\infty}^t m(\alpha) d\alpha \right]$$

where $k = k' k''$

The instantaneous angular frequency is

$$\omega_i = \frac{d}{dt} \left[\omega_c t + k \int_{-\infty}^t m(\alpha) d\alpha \right] = \omega_c + k m(t)$$

The deviation of the instantaneous frequency from the carrier frequency $\omega_c/2\pi$ is

$$\Delta f = f_i - f_c = \frac{k}{2\pi} m(t)$$

Since the deviation of the instantaneous frequency is directly proportional to the modulating signal, the combination of integrator and phase modulator of the above figure constitutes a device for frequency modulation.

Diagrammatically comparison of AM, FM & PM:

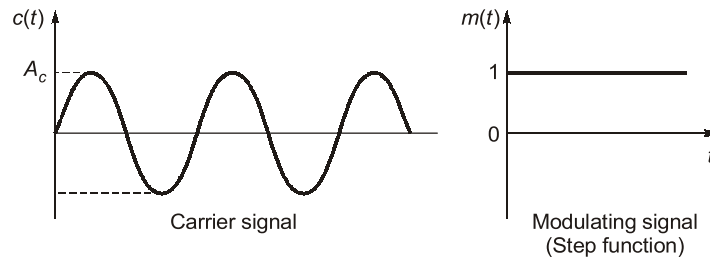

AM signal:

$$s_{AM}(t) = A_c(1 + K_a m(t)) \cos 2\pi f_c t$$

$$= A_c(1 + K_a) \cos 2\pi f_c t$$

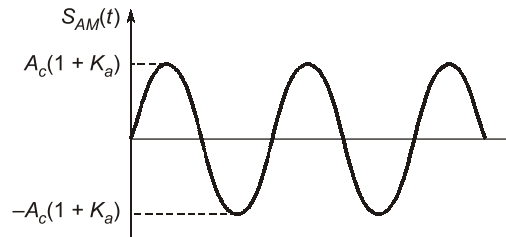

FM signal:

$$s_{FM}(t) = A_c \cos \left(2\pi f_c t + 2\pi K_f \int_{-\infty}^t m(t) dt \right)$$

$$= A_c \cos(2\pi f_c t + 2\pi K_f t)$$

$$= A_c \cos[2\pi(f_c + K_f)t]$$

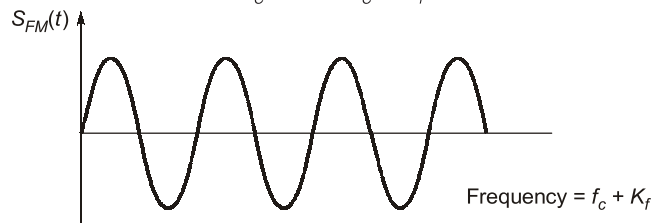

PM signal:

$$s_{PM}(t) = A_c \cos(2\pi f_c t + K_p m(t))$$

$$= A_c \cos(2\pi f_c t + K_p)$$

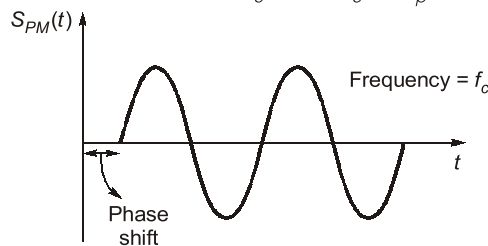

- 1.4** In a radio broadcast transmitter, the carrier signal is sinusoidal with amplitude of 3 volt and frequency of 15 kHz. The carrier signal is modulated by a square wave that does not have any dc component, yet does have peak-to-peak amplitude of 2.0 volt and frequency of 2 kHz. Write down the mathematical expressions of the carrier signal, the modulating signal and the modulated signal. Neatly plot those waveforms as a function of time. Obtain the plots in frequency domain as well.

[10 marks : 2004]

Solution:

Carrier signal, $v_c(t) = V_c \sin \omega_c t$

$$= 3 \sin(2\pi \times 15 \times 10^3 t) \text{ V} = 3 \sin(30\pi \times 10^3 t) \text{ V}$$

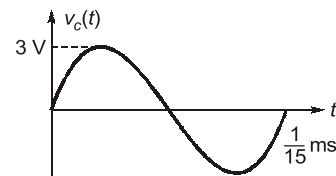

Modulating signal,
$$v_m(t) = \begin{cases} 1, & 0 < t < \frac{T}{2} \\ -1, & \frac{T}{2} < t < T \end{cases} \dots(i)$$

where,
$$T = \frac{1}{f_m} = \frac{1}{2 \times 10^3} = 5 \times 10^{-4} \text{ sec}$$

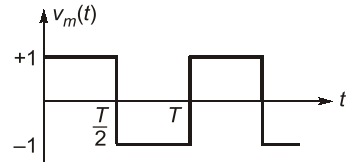

$v_m(t)$ is an odd signal with half wave symmetry. So, its trigonometric Fourier series representation has only b_n terms for odd values of n .

$$a_0 = a_n = 0$$

$$b_n = \frac{2}{T} \int_0^T v_m(t) \sin(n\omega_m t) dt = \frac{2}{T} \left[\int_0^{T/2} \sin(n\omega_m t) dt - \int_{T/2}^T \sin(n\omega_m t) dt \right]$$

$$= 2 \left[\frac{1 - \cos(n\pi)}{n\pi} \right]; n = 1, 2, 3 \dots$$

So, modulating signal,
$$V_m(t) = \frac{4}{\pi} \sin 2\pi f_m t + \frac{4}{3\pi} \sin 6\pi f_m t + \frac{4}{5\pi} \sin 10\pi f_m t + \dots$$

Modulated signal,

$$s(t) = (v_c + v_m) \sin \omega_c t$$

where, $v_m(t)$ as defined (i)

$$\therefore s(t) = [v_c + v_m(t)] \sin \omega_c t$$

Plots in frequency domain, for carrier signal

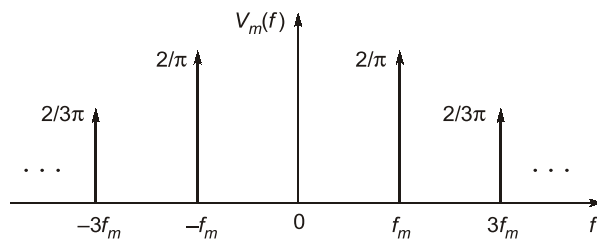
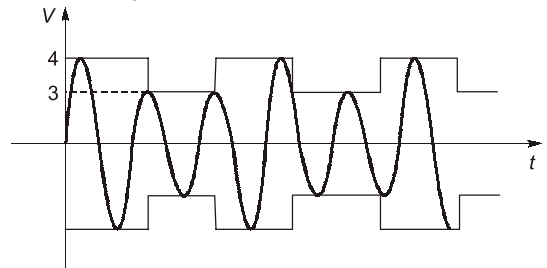
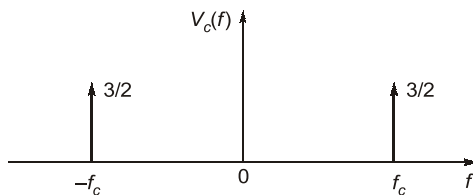

Modulated signal
$$s(t) = [V_c + V_m(t)] \sin \omega_c t$$

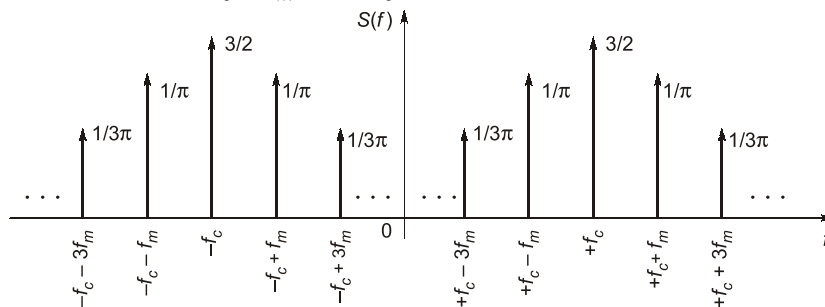

- 1.5** A 50 MHz carrier delivers 100 W power to a load. The carrier is now frequency modulated by a 1 kHz modulating signal causing a maximum frequency deviation of 6 kHz. This frequency modulated signal is now coupled to the load through an ideal band-pass filter with 50 MHz center frequency and a variable bandwidth. Calculate the power delivered to the load when the filter bandwidth is
 (a) 1 kHz (b) 2.1 kHz (c) 12.5 kHz (d) 14.5 kHz (e) 20.2 kHz

Comment on the result. Given:

$$J_0(6) = 0.1506 ; J_1(6) = -0.2767 ; J_2(6) = -0.2429 ; J_3(6) = 0.1148 ; J_4(6) = 0.3576 ; J_5(6) = 0.3621$$

$$J_6(6) = 0.2458 ; J_7(6) = 0.1296 ; J_8(6) = 0.0565 ; J_9(6) = 0.0212 ; J_{10}(6) = 0.0060$$

[15 marks : 2008]

Solution:

Given that: Carrier frequency, $f_c = 50$ MHz, $f_m = 1$ kHz, $\Delta f = 6$ kHz and $P_c = 100$ W

We know that, Modulation index (β) = $\frac{\Delta f}{f_m} = \frac{6 \times 10^3}{1 \times 10^3} = 6$

Equation of FM,
$$x_{FM}(t) = A_C \sum_{k=-\infty}^{\infty} J_k(\beta) \cos\{(\omega_c + k\omega_m)t\}$$

So, power $P = \sum_{k=-\infty}^{\infty} \frac{A_C^2}{2} \cdot J_k^2(\beta) = \sum_{k=-\infty}^{\infty} P_C \cdot J_k^2(\beta)$

$$P_k = P_C J_k^2(\beta)$$

For $k = 0$

Frequency component = $f_c \pm 0 = f_c$

$$P_0 = P_C \times J_0^2(\beta) = 100 \times (0.1506)^2 = 2.268 \text{ Watt}$$

For $k = 1$ and -1

Frequency component = $f_c \pm f_m = 1 \text{ MHz} \pm 1 \text{ kHz}$

Also, $J_{-n}(\beta) = (-1)^n J_n(\beta)$ i.e. $J_{-1}(\beta) = J_1(\beta)$

$$P_1 = P_C \times J_1^2(\beta) = 100 \times (-0.2767)^2 = 7.656 \text{ Watt}$$

Similarly we can find out the power of other frequency component.

k	Frequency component ($f_c \pm kf_m$)	Power (W)
0	50 MHz	2.268
± 1	50 MHz \pm 1 kHz	7.656
± 2	50 MHz \pm 2 kHz	5.900
± 3	50 MHz \pm 3 kHz	1.318
± 4	50 MHz \pm 4 kHz	12.788
± 5	50 MHz \pm 5 kHz	13.112
± 6	50 MHz \pm 6 kHz	6.042
± 7	50 MHz \pm 7 kHz	1.679
± 8	50 MHz \pm 8 kHz	0.319
± 9	50 MHz \pm 9 kHz	0.0449
± 10	50 MHz \pm 10 kHz	3.6×10^{-3}

The magnitude spectrum, for positive frequencies, of a wideband FM signal is,

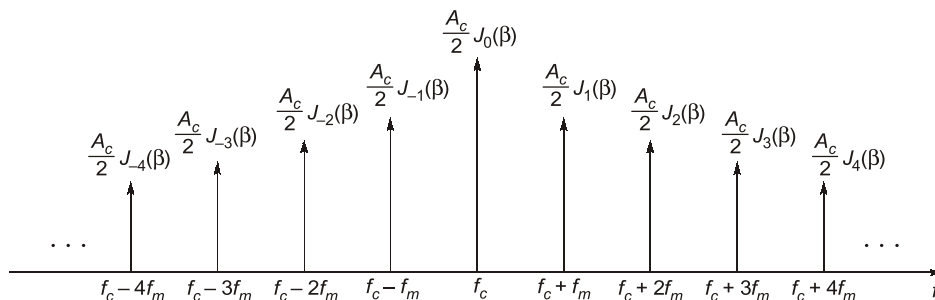

Case-1

BW = 1 kHz

Then it will pass only single component i.e. f_c

so $P = 2.268 \text{ W}$

Case-2 $BW = 2.1 \text{ kHz}$

So output of filter will contain 3 frequency component

i.e. $f_c; f_c \pm f_m$

So $P = 2.268 + 2(7.656)$

$P = 17.58 \text{ Watt}$

Case-3 $BW = 12.5 \text{ kHz}$

So output of filter will contain

$f_c; f_c \pm f_m; f_c \pm 2f_m; f_c \pm 3f_m; f_c \pm 4f_m; f_c \pm 5f_m; f_c \pm 6f_m$

so power delivered to load

$P = 2.268 + 2(7.656 + 5.9 + 1.318 + 12.788 + 13.112 + 6.042)$

$P = 95.9 \text{ Watt}$

Case-4 $BW = 14.5 \text{ kHz}$

So output of filter will contain

$f_c; f_c \pm f_m; f_c \pm 2f_m; f_c \pm 3f_m; f_c \pm 4f_m; f_c \pm 5f_m; f_c \pm 6f_m; f_c \pm 7f_m$

so power delivered to load

$P = 2.268 + 2(7.656 + 5.9 + 1.318 + 12.788 + 13.112 + 6.042 + 1.679)$

$P = 99.258 \text{ Watt}$

Case-5 $BW = 20.2 \text{ kHz}$

So output of filter will contain

$f_c; f_c \pm f_m; f_c \pm 2f_m; f_c \pm 3f_m; f_c \pm 4f_m; f_c \pm 5f_m; f_c \pm 6f_m; f_c \pm 7f_m; f_c \pm 8f_m; f_c \pm 9f_m; f_c \pm 10f_m$

so power delivered to load

$P = 2.268 + 2(7.656 + 5.9 + 1.318 + 12.788 + 13.112 + 6.042 + 1.679$

$+ 0.319 + 0.0449 + 3.6 \times 10^{-3})$

$P = 99.99 \text{ Watt}$

○ Comments on the Results:

- The transmission B.W of an FM wave as the separation between the two frequencies beyond which none of the side-frequencies is greater than 1% of the carrier amplitude obtained when the modulation is removed.
- As the value of n_{\max} increases here the power delivered to the load may also be increased. Because as the modulation index (β) increases, the B.W occupied by the significant side-frequencies drops towards that over which the carrier frequency actually deviates i.e. carrier power decreases and sideband power increases.

1.6 With the help of a block diagram explain the working of a superheterodyne AM receiver.

[10 marks : 2009]

Solution:

A radio receiver is an electronic equipment which picks up the desired signal, rejects the unwanted signal, amplifies the desired signal, demodulates the modulated signal to obtain back the original modulating signal.

⇒ The usual AM radio receiver of superheterodyne (mixing) type is represented schematically in figure below:

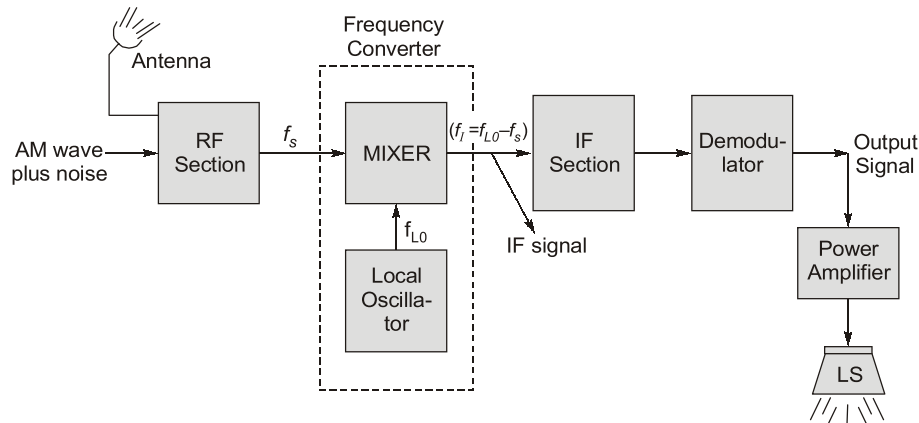

(Superheterodyne AM Radio Receiver)

Basically this receiver consists of RF section, a mixer and a local oscillator, an intermediate frequency (IF) section and a demodulator.

Working:

- The incoming AM wave is picked up by the receiving antenna and amplified in the RF section which is tuned to the carrier frequency of the incoming wave.
- The combination of mixer and local oscillator (of adjustable frequency) provides a frequency conversion or heterodyning function, where the incoming signal is converted to a predetermined fixed IF (usually lower than the signal frequency). The mixer-local oscillator combination is sometimes referred to as the **First detector**, in this case the Demodulator is called the **Second detector**.
- The IF section consists of one or more stages of tuned amplification. This section provides most of the amplification i.e. sensitivity and selectivity (B.W requirements) in the receiver. Because of its narrow Bandwidth, the IF amplifier rejects all other frequency except intermediate frequency (IF). Actually, this rejection reduces the risk of interference from other stations or sources. Infact, this selection process is the key to the superheterodyne receivers exceptional performance.
- The output of the IF section is then applied to the demodulator, the purpose of which is to recover the baseband or modulating signal. If coherent detection is used, then a coherent signal source must be provided in the receiver. The final operation in the receiver is the power amplification so that it make activate the Loudspeaker.
- The Loudspeaker (LS) is a transducer which converts this audio electrical signal into audio sound signal and thus original signal is reproduced i.e., the original transmission is received.

⇒ **Typical frequency parameters of commercial AM Radio receiver is as follows:**

RF carrier range = 0.535 – 1.605 MHz

Mid-band frequency of IF section = 455 kHz \approx 0.455 MHz

IF Bandwidth = 10 kHz.

⇒ **The advantages of superheterodyne receiver** make it the most suitable for the majority of radio receiver applications like AM, FM, communications, single-sideband, TV and even Radar receiver; all uses superheterodyne principle.

1.7 In a FM system, when the audio frequency (AF) is 500 Hz and the AF voltage is 2.4 volt, and frequency deviation is 4.8 kHz if voltage is increased to 7.2 V, what is the new deviation? Now, if the AF voltage is raised to 10 V and AF is dropped to 200 Hz, what is the deviation? Find the modulation index in each case.

Mention two disadvantages of FM over AM.

[10 marks: 2010]

Solution:

$$\begin{aligned} \text{Audio frequency } f_m &= 500 \text{ Hz} \\ A_m &= 2.4 \text{ V} \\ \text{Deviation } \Delta f &= 4.8 \text{ kHz} \end{aligned}$$

We know that

$$\begin{aligned} \text{Modulation index } \beta &= \frac{\Delta f}{f_m} = \frac{4.8 \times 10^3}{500} \\ \beta &= 9.6 \end{aligned}$$

$$\begin{aligned} \text{and } \text{Deviation } \Delta f &= k_f A_m \\ 4.8 \times 10^3 &= k_f \times 2.4 \\ k_f &= 2 \times 10^3 \text{ Hz/V} \end{aligned}$$

$$\begin{aligned} \text{(i) Now } A_m &= 7.2 \text{ V} \\ \text{Deviation } \Delta f &= k_f A_m && [\text{where } k_f = \text{frequency sensitivity}] \\ \Delta f &= 2 \times 10^3 \times 7.2 = 14.4 \text{ kHz} \end{aligned}$$

$$\begin{aligned} \text{Modulation index, } \beta &= \frac{\Delta f}{f_m} = \frac{14.4 \times 10^3}{500} \\ \beta &= 28.8 \end{aligned}$$

$$\begin{aligned} \text{(ii) } A_m &= 10 \text{ V; } f_m = 200 \text{ Hz} \\ \text{Deviation } \Delta f &= k_f A_m = 2 \times 10^3 \times 10 = 20 \times 10^3 = 20 \times 10^3 \text{ Hz} \\ \Delta f &= 20 \text{ kHz} \end{aligned}$$

$$\text{Modulation index, } \beta = \frac{\Delta f}{f_m} = \frac{20 \times 10^3}{200} = 100$$

Disadvantage of FM over AM:

1. Threshold effect is more pronounced in FM than AM.
2. Circuit is more complex.
3. FM required more bandwidth than AM because bandwidth for FM is 10 times greater than AM.

1.8 Consider a modulating signal

$$m(t) = 10 \sin(2\pi \times 10^4 t)$$

that is used to modulate a carrier frequency of 25 MHz.

- (i) Find the bandwidth for 98% power transmission for phase modulation and frequency modulation using $\beta_p = 10$ and $\beta_f = 10$.
- (ii) Repeat (i) when modulating frequency is doubled.
- (iii) Repeat (ii) when amplitude of the modulating signal is halved.

[10 marks : 2011]

Solution:

Given that message signal

$$m(t) = 10 \sin(2\pi \times 10^4 t)$$

$$\therefore f_m = 10^4 \text{ Hz} = 10 \text{ kHz} \quad \dots(i)$$

$$\text{Carrier frequency } f_c = 25 \text{ MHz}$$

$$\text{(i) Given that } \beta_p = 10, \beta_f = 10$$

$$\text{We know that, } \beta_p = \frac{K_p A_m}{f_m}$$

Where $K_p A_m$ maximum phase deviation

$$\beta_p = \frac{K_p \times 10}{10^4}$$

$$K_p = \frac{10 \times 10^4}{10} = 10^4 \text{ rad/V} \quad \dots(ii)$$

$K_p \rightarrow$ phase deviation constant

$$\beta_f = \frac{K_f A_m}{f_m} \quad K_f - \text{frequency deviation constant}$$

$$K_f = 10^4 \text{ Hz/V} \quad \dots(iii)$$

Effective bandwidth of angle modulated signal which contains atleast 98% of the signal power is given by Carson's rule

$$\text{B.W.} = 2(\beta + 1)f_m$$

\therefore (i) for phase modulated signal

$$\text{B.W.} = 2(\beta_p + 1)f_m$$

$$\text{B.W.} = 2(10 + 1) \times 10^4$$

$$\boxed{\text{B.W.} = 220 \text{ kHz}} \text{ for PM.}$$

$\therefore \beta_p = \beta_f$

\therefore B.W. of frequency modulated signal will be same

$\therefore \boxed{\text{B.W. of FM modulated signal} = 220 \text{ kHz}}$ for FM

(ii) When modulating frequency is doubled

i.e. $f'_m = 2f_m = 2 \times 10^4 \text{ Hz}$

\therefore New modulation index for phase modulated and frequency modulated signals.

$$\beta'_p = \frac{K_p A_m}{f'_m} = \frac{10^4 \times 10}{2 \times 10^4} = 5$$

$$\beta'_f = \frac{K_f A_m}{f'_m} = \frac{10^4 \times 10}{2 \times 10^4} = 5$$

\therefore B.W. of phase modulated signal

$$\text{B.W.} = 2(\beta'_p + 1)f'_m$$

$$\text{B.W.} = 2(5 + 1) \times 2 \times 10^4$$

$$\boxed{\text{B.W.} = 240 \text{ kHz}} \text{ for PM}$$

$\therefore \beta'_p = \beta'_f$

\therefore B.W. of frequency modulated signal

$$\boxed{\text{B.W.} = 240 \text{ kHz}} \text{ for FM}$$

(iii) Now amplitude of modulating signal is halved.

$$A'_m = A_m/2 = 10/2 = 5$$

\therefore New modulation index of phase and frequency modulated signals.

$$\beta''_p = \frac{K_p A'_m}{f'_m} = \frac{10^4 \times 5}{2 \times 10^4} = 2.5 = 2.5$$

∴ New bandwidth of phase and frequency modulated signals

$$\text{B.W.} = 2(\beta_p'' + 1)f_m'$$

$$\text{B.W.} = 2(2.5 + 1) \times 2 \times 10^4$$

$$\boxed{\text{B.W.} = 140 \text{ kHz}} \text{ for PM}$$

$$\therefore \beta_p'' = \beta_f''$$

⇒ B.W. for both signals will be same.

∴ B.W. of frequency modulated signal will be

$$\boxed{\text{B.W.} = 140 \text{ kHz}} \text{ for FM}$$

1.9 In an AM Transmitter, antenna current is 8 amperes, when only the carrier is sent but is increased to 8.93 amperes when carrier is modulated by a single sine wave. Determine the percentage of Modulation. Also evaluate the antenna current when the percentage of Modulation is changed to 80%.

[10 marks : 2012]

Solution:

We know that, for single sine wave modulation

$$\boxed{P_t = P_c \left(1 + \frac{m^2}{2} \right)}$$

...(i)

where,

P_t = Total transmitted power

P_c = Carrier power

m = Modulation index

$$P_t = I_t^2 R$$

$$P_c = I_c^2 R$$

Substitute the values of P_t and P_c in equation (i)

$$I_t^2 R = I_c^2 R \left(1 + \frac{m^2}{2} \right)$$

$$I_t^2 = I_c^2 \left(1 + \frac{m^2}{2} \right)$$

$$\boxed{I_t = I_c \sqrt{1 + \frac{m^2}{2}}}$$

Given that

$$I_t = 8.93 \text{ Amp.}$$

$$I_c = 8 \text{ Amp}$$

$$m = ?$$

So,

$$8.93 = 8 \sqrt{1 + \frac{m^2}{2}}$$

$$\sqrt{1 + \frac{m^2}{2}} = \frac{8.93}{8} = 1.116$$

$$1 + \frac{m^2}{2} = 1.246$$

$$\frac{m^2}{2} = 0.246$$

$$m^2 = 0.492$$

$$m = 0.7014 \quad \text{Ans.}$$

$$\%m = 0.7014 \times 100 = 70.14\% \quad \text{Ans.}$$

Given that

$$I_c = 8 \text{ Amp}$$

$$m = 80\% = \frac{80}{100} = 0.8$$

$$I_t = ?$$

We know that,

$$I_t = I_c \sqrt{1 + \frac{m^2}{2}} = 8 \sqrt{1 + \frac{(0.8)^2}{2}} = 8 \sqrt{1 + 0.32} = 8 \sqrt{1.32}$$

$$I_t = 9.1913 \text{ Amp}$$

1.10 Find the carrier and modulating frequencies, the modulation index and the maximum deviation of the FM wave represented by the voltage equation

$$v = 12 \sin(6 \times 10^8 t + 5 \sin 1250 t)$$

What power will this FM wave dissipate in a 10Ω resistor?

[5 marks : 2014]

Solution:

$$v(t) = 12 \sin(6 \times 10^8 t + 5 \sin 1250 t)$$

Single-tone F.M. modulated wave equation can be given by,

$$v(t) = A \sin[\omega_c t + k_f \int V_m \cos(\omega_m t) dt] \quad \dots(i)$$

Where, ω_c is carrier frequency and $V_m \cos \omega_m t$ is modulating signal.

For single tone modulation the above equation reduces to

$$V_{in} = A \sin[\omega_c t + \beta \sin(\omega_m t)] \quad \dots(ii)$$

where,

$$\beta = \text{modulation index} = \frac{\Delta f}{f_m}$$

Thus, comparing the equation (ii) with the given equation, we get,

$$\omega_c = 2\pi f_c = 6 \times 10^8$$

$$\therefore f_c = \frac{6 \times 10^8}{2\pi} = 95.49 \text{ MHz}$$

$$f_m = \frac{1250}{2\pi} = 198.94 \text{ Hz}$$

$$\beta = 5$$

Now, the frequency deviation can be given as

$$\Delta f = f_m \cdot \beta = 5 \times 198.94 = 995 \text{ Hz}$$

Power dissipated in 10Ω resistor

$$P = \frac{V_m^2}{2R} = \frac{12^2}{2 \times 10} = 7.2 \text{ W}$$

1.11 (i) The antenna current of an AM broadcast transmitter, modulated to a depth of 40 percent by an audio sine wave, is 11 amperes. It increases to 12 amperes as a result of simultaneous modulation by another audio sine wave. What is the modulation index due to this second wave?

(ii) A certain transmitter radiates 9 kW with the carrier unmodulated and 10.125 kW when the carrier is simultaneously modulated. Estimate the modulation index. If another sine wave, corresponding to 40% modulation, is transmitted simultaneously, find out the total radiated power.

[5 + 5 marks : 2015]

Solution:

(i) Given that,

depth of modulation,

$$\mu_1 = 40\% = 0.4$$

Antenna current,

$$I_t = 11 \text{ A}$$

$$I_t^2 = I_c^2 \left(1 + \frac{\mu_1^2}{2} \right)$$

$$I_c = I_t \sqrt{\frac{1}{1 + \frac{\mu_1^2}{2}}} = 11 \sqrt{\frac{1}{1 + \frac{(0.4)^2}{2}}} = 10.58 \text{ A}$$

Now, given that

antenna current

$$I_t = 12 \text{ A}$$

Let the second modulated wave be of modulation index μ_2

$$I_t^2 = I_c^2 \left(1 + \frac{\mu_1^2}{2} + \frac{\mu_2^2}{2} \right)$$

$$(12)^2 = (10.58)^2 \left(1 + \frac{(0.4)^2}{2} + \frac{\mu_2^2}{2} \right)$$

From here,

$$\mu_2 = 0.64$$

(ii) Given that, Carrier power,

$$P_c = 9 \text{ kW}$$

Total power,

$$P_t = 10.125 \text{ kW}$$

Let modulation depth is μ_1

$$P_t = P_c \left(1 + \frac{\mu_1^2}{2} \right)$$

$$10.125 = 9 \left(1 + \frac{\mu_1^2}{2} \right)$$

From here

$$\mu_1 = \frac{1}{2} \text{ or } 50\%$$

Simultaneous modulated with $\mu_2 = 40\%$

$$P_t = P_c \left(1 + \frac{\mu_1^2}{2} + \frac{\mu_2^2}{2} \right) = 9 \left(1 + \frac{(0.5)^2}{2} + \frac{(0.4)^2}{2} \right) \text{ kW} = 10.845 \text{ kW}$$

1.12 Explain and differentiate between baselband communication and carrier communication. An audio FM system with audio frequency of 1 kHz and audio frequency voltage of 4.8 V is used with frequency deviation of 7.2 kHz. Calculate modulation index. If the voltage of audio signal now increased to 8.2 V, what is new deviation? Now if both audio voltage and frequency are changed to 10 V and 200 Hz calculate deviation and modulation Index.

[10 marks : 2017]

Solution:

Baseband Communication: In a baseband communication system, the source information (baseband signal) will be transmitted to the destination in it's original frequency range. No modulation is used in this communication technique.

Carrier Communication: In a carrier communication system, the source information is modulated on to a high frequency carrier signal and the modulated signal will be transmitted to the destination.

S. No.	Baseband Communication	Carrier Communication
1.	No modulation is used.	Modulation is used.
2.	Signal should be transmitted through a private physical medium (co-axial cables, twisted pair cable, waveguides etc.)	Signal can be transmitted through both physical mediums and free space.
3.	Frequency division multiplexing is not possible	Frequency division multiplexing is possible.
4.	Time division multiplexing is possible	Time division multiplexing is possible
5.	Example: Public addressing system	Example FM and AM broadcasting

Given data:

Audio frequency, $f_m = 1 \text{ kHz}$
 Audio frequency voltage, $A_m = 4.8 \text{ V}$
 Frequency deviation, $\Delta f = 7.2 \text{ kHz}$

The modulation index β of the FM signal with above parameters can be given as,

$$\beta = \frac{\Delta f}{f_m} = \frac{7.2}{1} = 7.2$$

When voltage (A_m) is increased to 8.2 V :

The frequency deviation (Δf_1) for the modified voltage (A_{m1}) can be given as,

$$\Delta f_1 = K_f A_{m1} = \frac{\Delta f}{A_m} \times A_{m1} = \frac{7.2 \text{ kHz}}{4.8 \text{ V}} \times 8.2 \text{ V} = 12.3 \text{ kHz}$$

When both audio voltage and frequency are changed to 10 V and 200 Hz respectively :

The frequency deviation (Δf_2) for the modified voltage (A_{m2}) and frequency (f_{m2}) can be given as,

$$\Delta f_2 = \frac{\Delta f}{A_m} \times A_{m2} = \frac{7.2 \text{ kHz}}{4.8 \text{ V}} \times 10 \text{ V} = 15 \text{ kHz}$$

$$\beta_2 = \frac{\Delta f_2}{f_{m2}} = \frac{15 \text{ kHz}}{200 \text{ Hz}} = \frac{15000}{200} = 75$$

1.13 Consider a message signal $m_1(t)$ as shown and message signal $m_2(t) = \text{sinc}(2 \times 10^4 t)$, in volts.

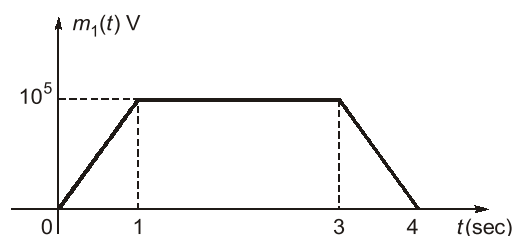

- If $m_1(t)$ is frequency modulated on a carrier with frequency 10^6 Hz with a frequency deviation constant (k_f) equal to 5 Hz/V , what is the maximum instantaneous frequency of the modulated signal?
- If $m_1(t)$ is phase modulated with phase deviation constant (k_p) equal to 3 rad/V , what is the maximum instantaneous frequency of the modulated signal? What is the minimum instantaneous frequency of the modulated signal?
- If $m_2(t)$ is frequency modulated with $k_f = 10^3 \text{ Hz/V}$, what is the maximum instantaneous frequency of the modulated signal? What is the bandwidth of the modulated signal?

[10 marks : 2018]